

REV.	ECN.NO.	MODIFY.CONTENT	DATE
A		NEW	2012/04/13

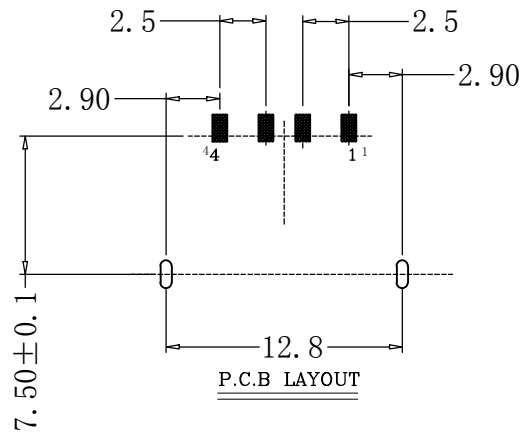
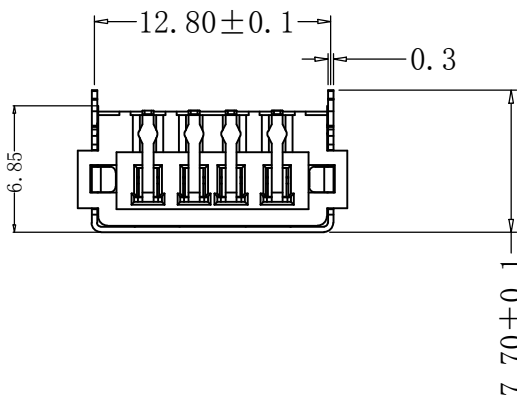
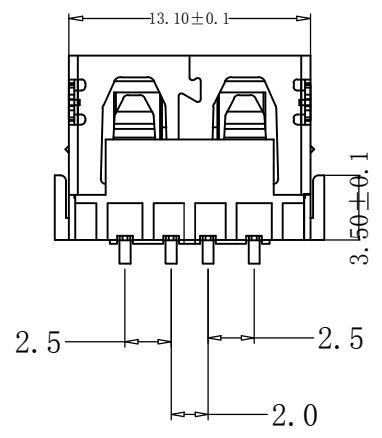
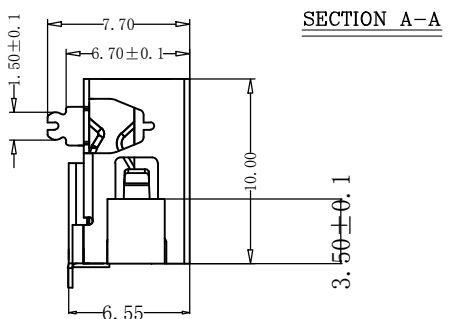
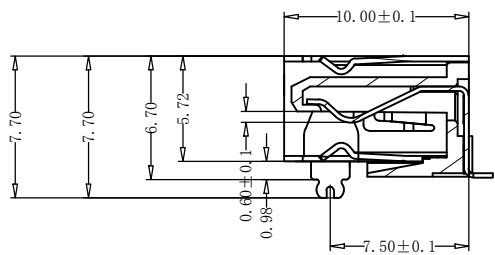
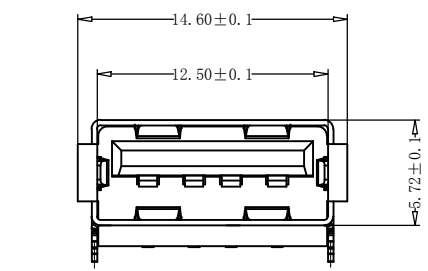

规格说明: Specifications:

电气特性: Electrical:

1. 额定电流: Current Rating
1.5A/contact terminal
2. 额定电压: Voltage Rating
30V DC
3. 接触阻抗: Contact Resistance
30 milliohms MAX
4. 耐电压: Dielectric Withstanding Voitage:
500 V AC AT Sea Level
5. 绝缘阻抗: Insulation Resistance:
1000MEGA ohms MIN

物理性能: Mechanical:

1. 插拔力: Connector Mate and Unmate Force
Mate force: 3.57kgf (MAX)
Unmate force: 1.02kgf (MIN)
2. 端子保持力: Terminal Retention
1.2kgf (MIN)

原材料: Material:

1. 塑胶: Housing:
Hing Temperature Tnermaplastics,
UL 94V-0 LCP White/Black
2. 端子: Contact: Copper Alloy C2680
3. 外壳: Shell: Copper Alloy C2680/SPCC

电镀: Finish:

1. 端子: Contact: Plated Gold in Mating Area;
Tin On Solder Talls
2. 外壳: Shell:
Nickel Plating

GENERAL TOLERANCE		DWG NO.	JYSA0804-001	APPD:	WIND	Scale	1:1
X.±0.45	x.'±5'	Title	USB A/F 90° DIP短体(10.00)	CHKD:		UNIT	mm
.X±0.35	.x'±2'			DR:			
.XX±0.25	.xx'±1'	Part NO.	JYS-USB650-013	Date	2012/04/13		
.XXX±0.15	.xxx'±0.5'	杰宇森电子有限公司 JIE YU SEN ELECTRONIC CO., LTD.					
SHEET	1/1						